

High Speedy Action
High Effective Performance.



VTW-755



VTW-540

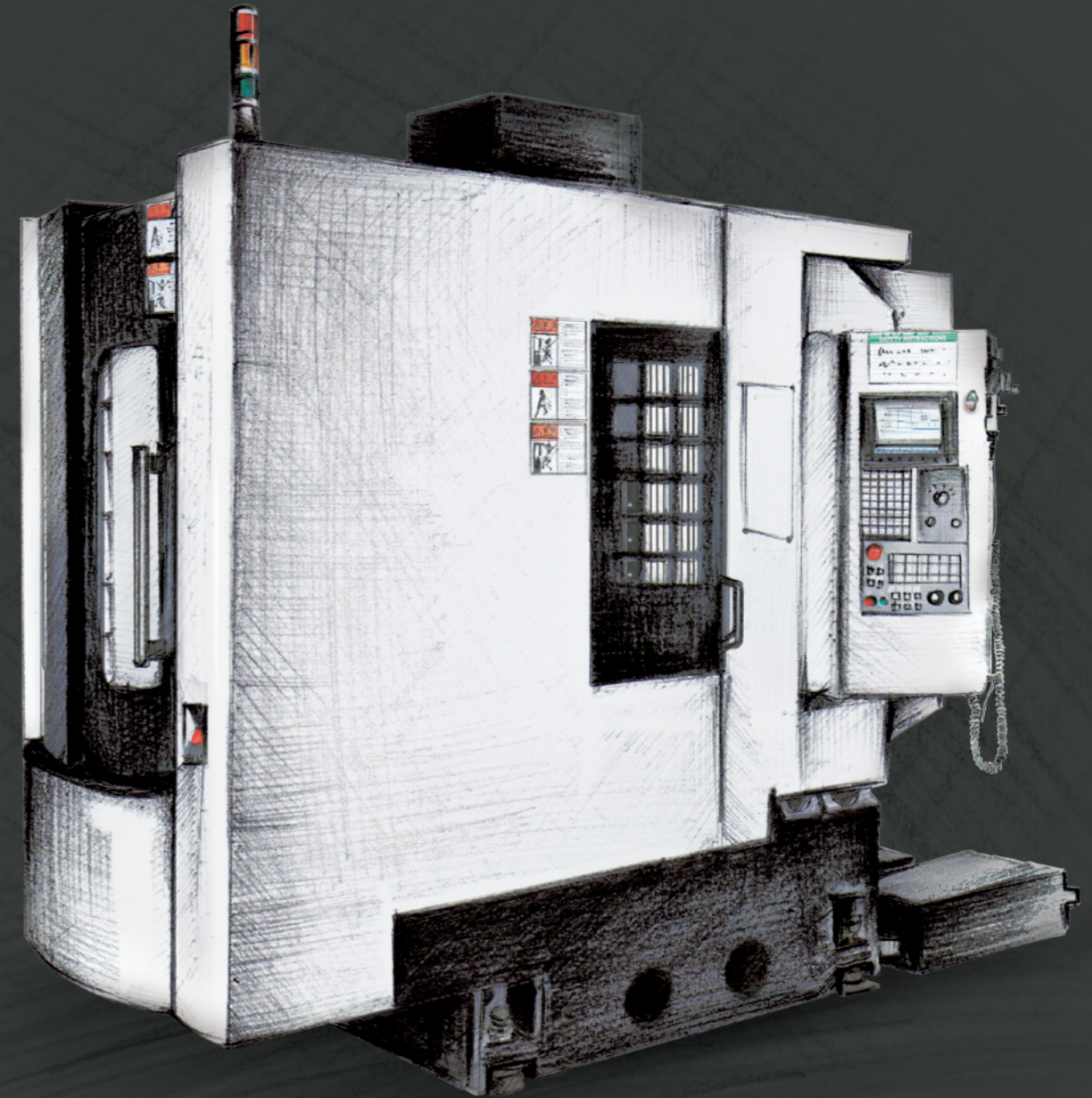

**Explosive
Momentum
VTW-540/755**

HIGH SPEED VERTICAL MACHINING CENTER WITH

2APC

Twinhorn

CHI-FA MACHINERY MANUFACTURER CO., LTD.

No. 44-8, MING-CHUNG RD., SHENG-KANG DIST.,
TAICHUNG CITY, TAIWAN 42948

Tel: +886-4-2562-8747 (Rep.)

Fax: +886-4-2561-4199

E-mail: inquiry@twinhorn.com.tw

www.twinhorn.com



Design 201902.VTW Series(E3)600P



VTW-540

MACHINE SPECIFICATION:

SPINDLE SPEED	15,000 rpm / 20,000 rpm / 24,000 rpm
TOOL CAPACITY	24+1 tools
X / Y / Z STROKE	500 x 400 x 350 mm
X / Y / Z RAPID FEEDRATE	48 / 48 / 48 M/min (opt. 60 / 60 / 60 M/min)
TOOL SHANK	BT30
TOOL CHANGE TIME	1.2 sec
PALLET CHANGE TIME	5 sec

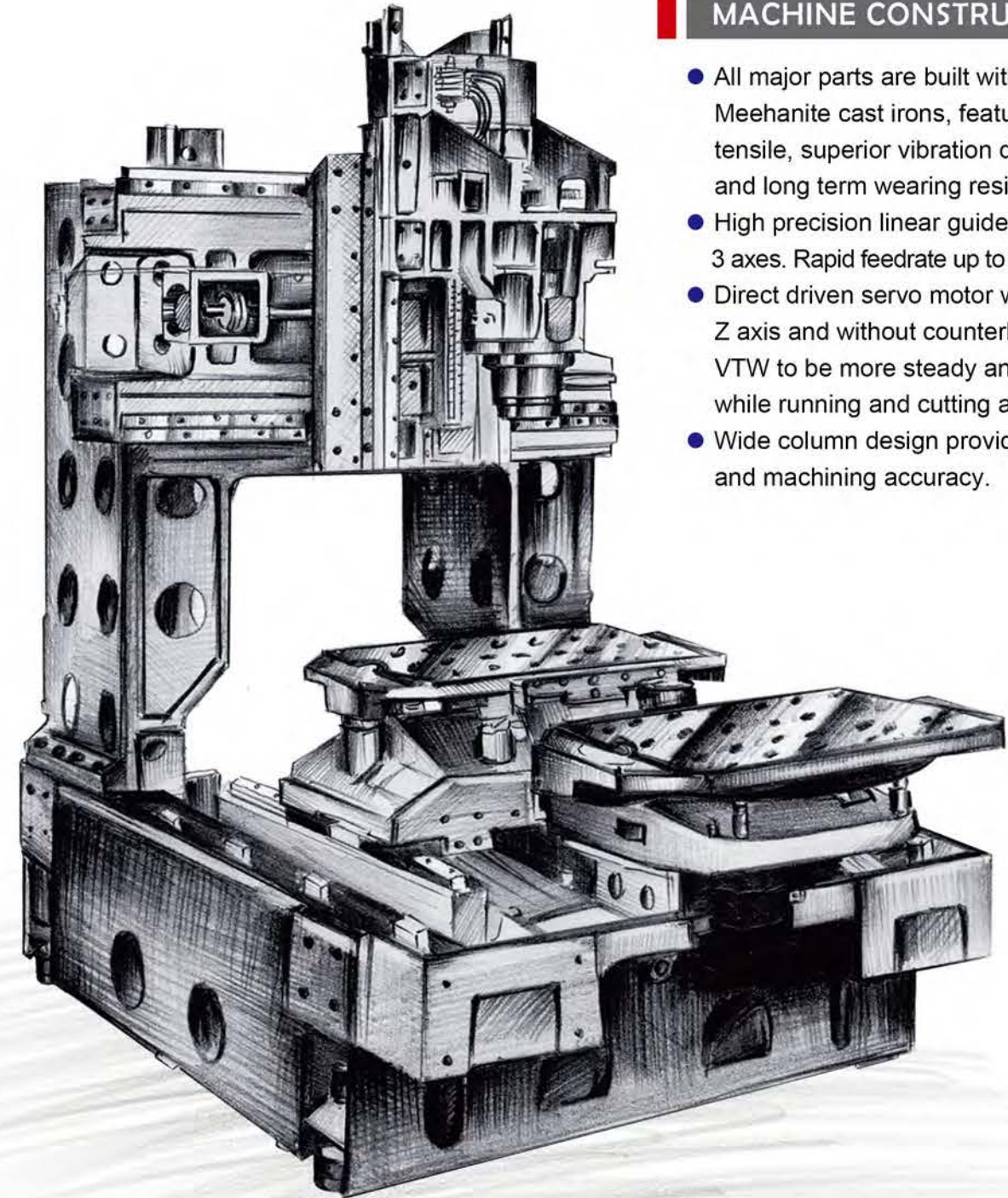

MACHINE CONSTRUCTION

- All major parts are built with certified Meehanite cast irons, featuring high tensile, superior vibration dampening and long term wearing resistance.
- High precision linear guide way on all 3 axes. Rapid feedrate up to 60 m/min.(opt.)
- Direct driven servo motor with brake on Z axis and without counterbalance allows VTW to be more steady and accurate while running and cutting at high speed.
- Wide column design provide high rigid and machining accuracy.

**2 pallet
APC Design**

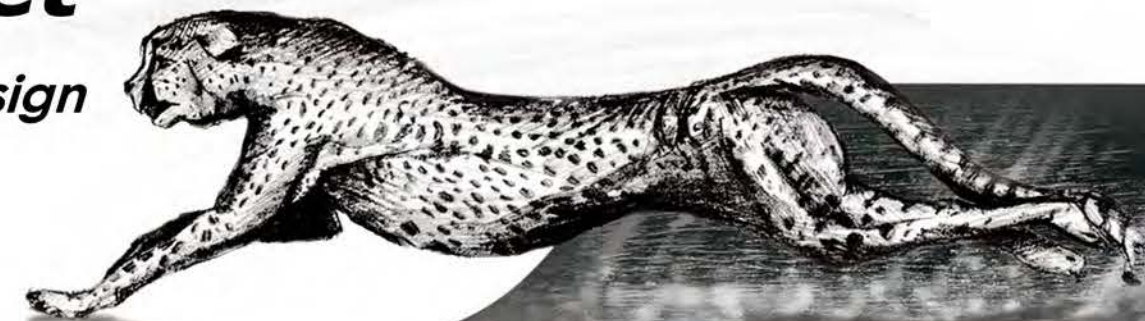



VTW-755

MACHINE SPECIFICATION:

SPINDLE SPEED	12,000 / 15,000 rpm
TOOL CAPACITY	30+1 tools
X / Y / Z STROKE	750 x 550 x 500 mm
X / Y / Z RAPID FEEDRATE	48 / 48 / 48 M/min(opt. 60 / 60 / 48 M/min)
TOOL SHANK	BBT40
TOOL CHANGE TIME	1.8 sec
PALLET CHANGE TIME	7 sec

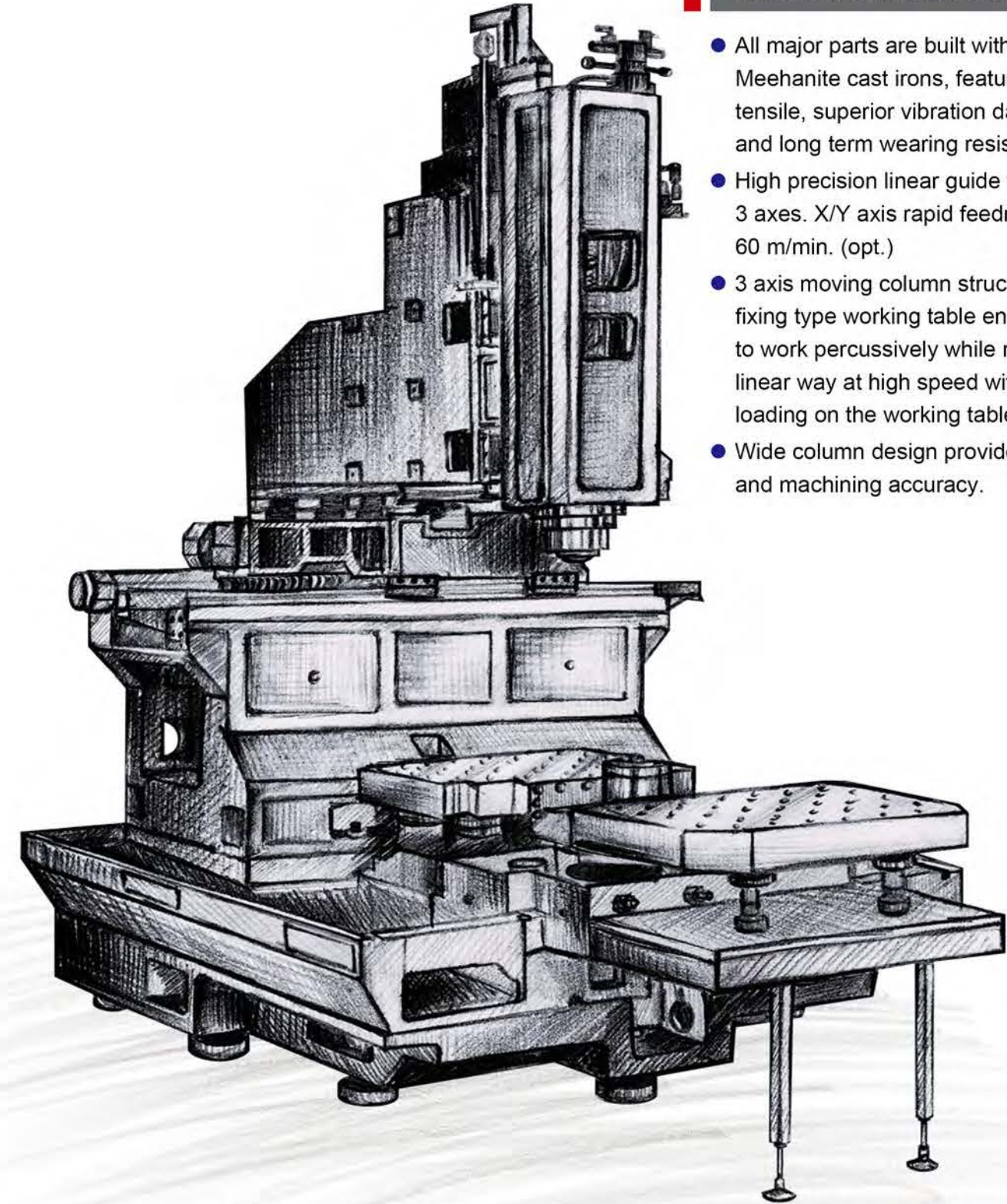

MACHINE CONSTRUCTION

- All major parts are built with certified Meehanite cast irons, featuring high tensile, superior vibration dampening and long term wearing resistance.
- High precision linear guide way on all 3 axes. X/Y axis rapid feedrate up to 60 m/min. (opt.)
- 3 axis moving column structure and fixing type working table ensures VTW to work percussively while running in linear way at high speed with heavier loading on the working table.
- Wide column design provide high rigid and machining accuracy.

**2 pallet
APC Design**



ATC SYSTEM

- High reliable ATC system. Rotating in two directions and exchanging the tool in random.



APC SYSTEM

- Pallet exchange in 180 degree. Driven by servo motor to ensure the working table running smoothly and steadily.
- Excellent high speed APC system to greatly grow up the machining efficiency and productivity



Removing the chips fast to solve chip accumulation problem.

HIGH CAPACITY COOLANT TANK

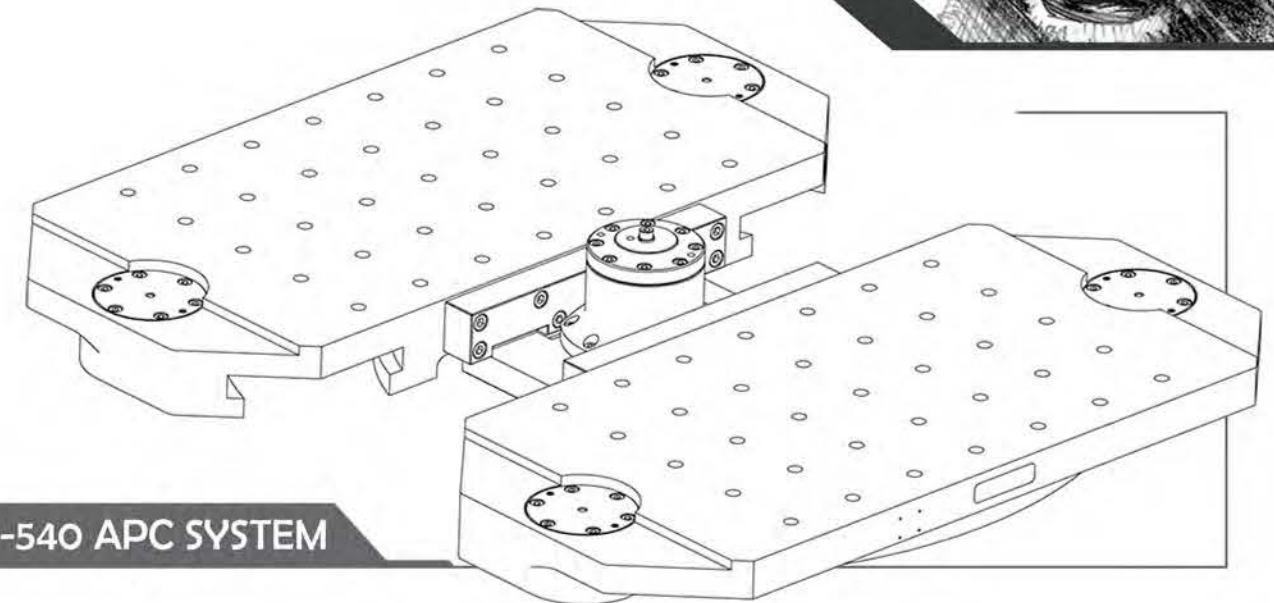

VTW-540 APC SYSTEM



BUILT-IN SPINDLE

DIRECT-DRIVEN SPINDLE

Built-in motor design to ensure the spindle runs with less noise, less vibration and without backlash. Spindle nose adopts labyrinth design and air curtain to prevent the dust entering into spindle interior to ensure the accuracy and life of the spindle.

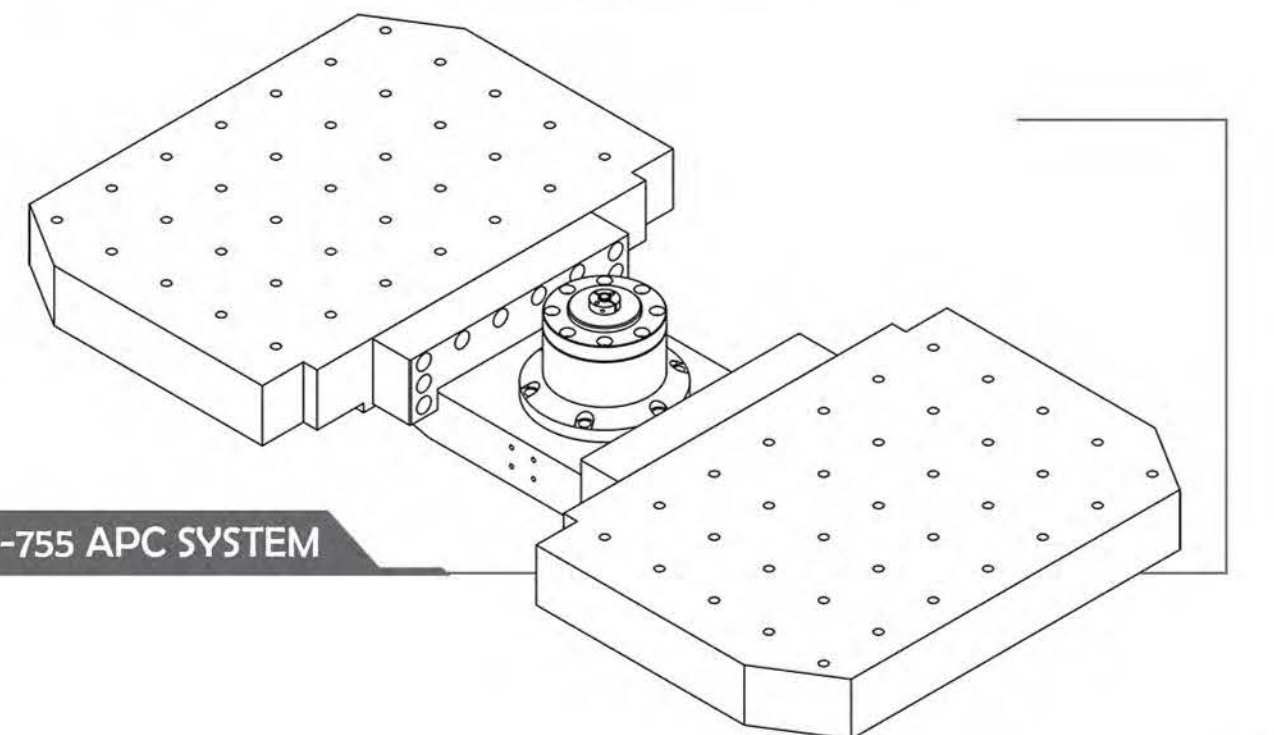

VTW-755 APC SYSTEM

VTW-540

INTERFERENCE-FREE MACHINING ROOM

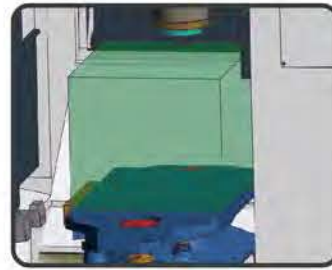
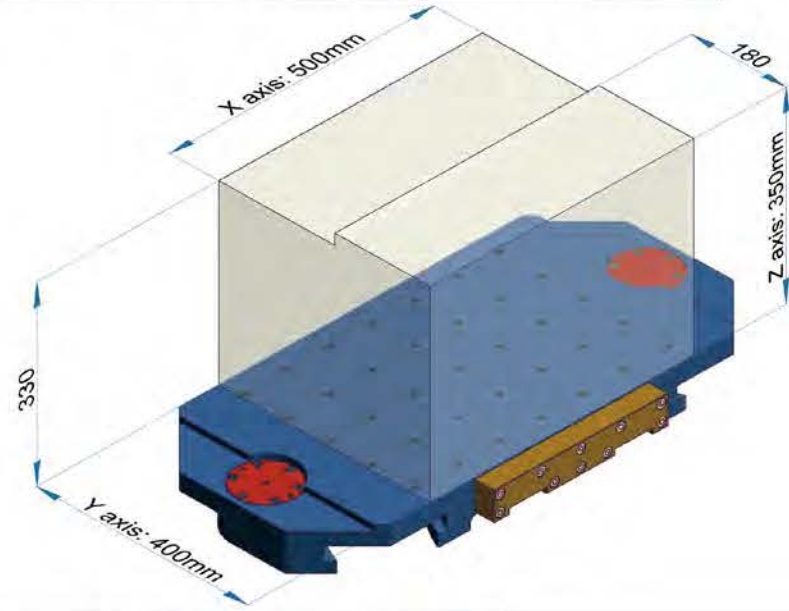

Machining range

VTW-755

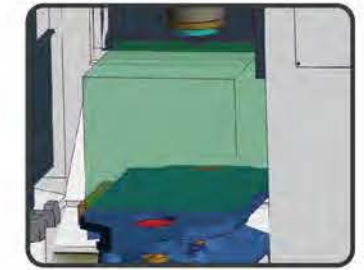
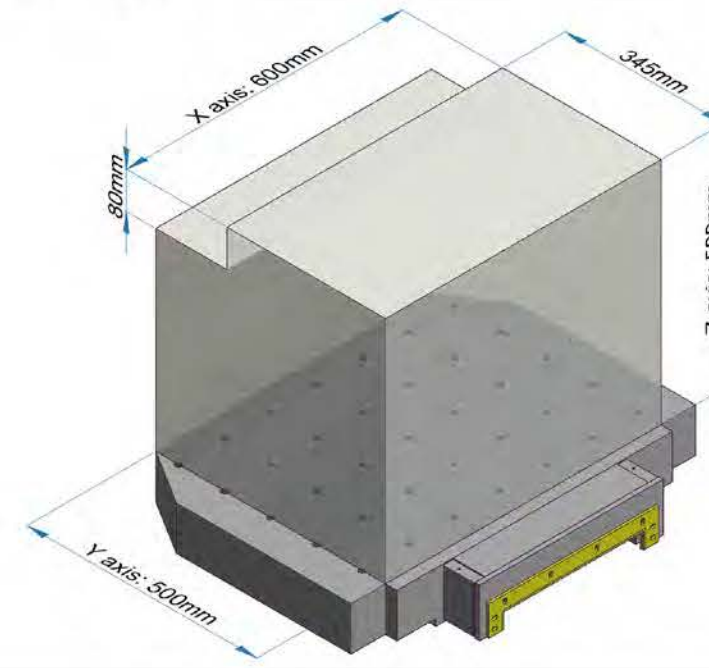

Machining range

EXAMPLE OF APPLICATION

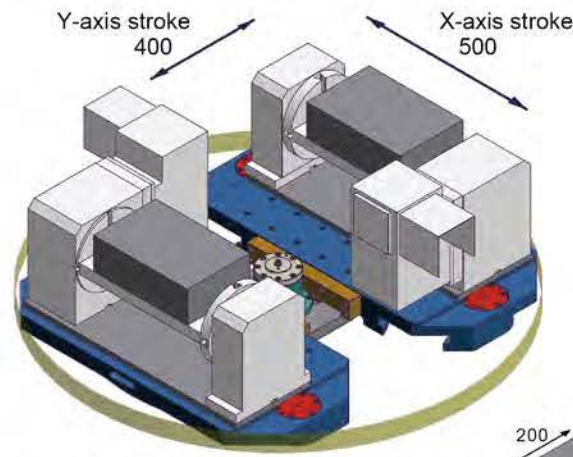

Turn diameter D1193

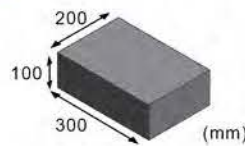

Turn diameter D1193

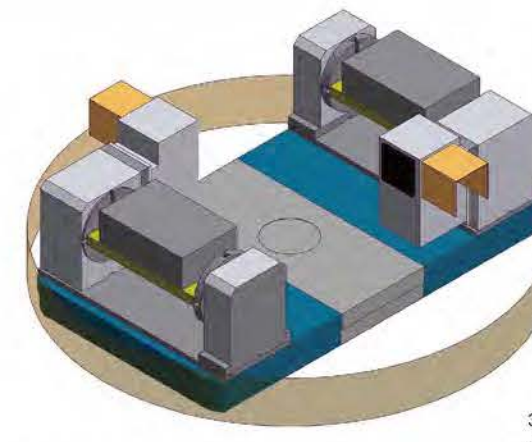
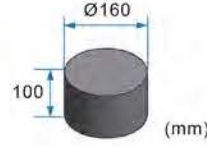
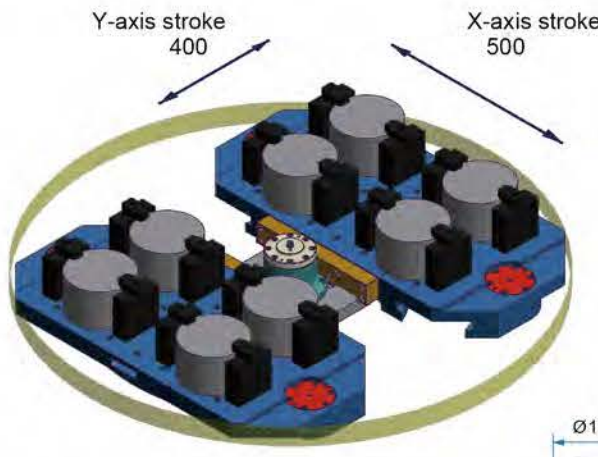

Turn diameter VTW-755:Ø1640

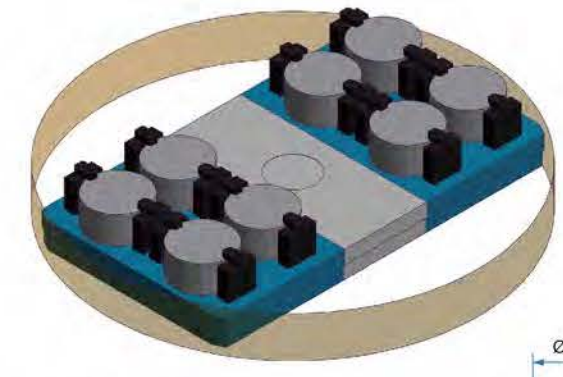
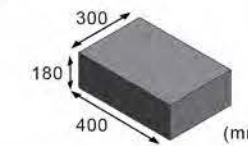

Turn diameter VTW-755:Ø1640

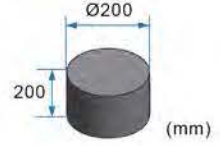

COMPARISON TABLE

BENEFIT OF TWO PALLET:

- Without any stop to load/unload workpiece or clean chip during machining process, no interruption with production.
- Ensure high & reliable production capacity.
- Load/unload workpiece during machining process, operator can handle different machine at the same time.

EXAMPLE OF HIGH PERFORMANCE:

- Allow for multiple set up of various workpieces as well as for multiple side of single workpiece without any time waste on fixture setting & clean, upgrade production capacity about 20%.

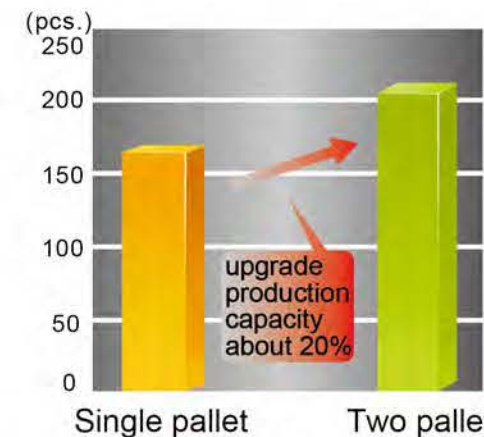

Machining time: 150sec / 1pc
 Load / unload time: 35sec / 1pc (10hrx85% operating rate)

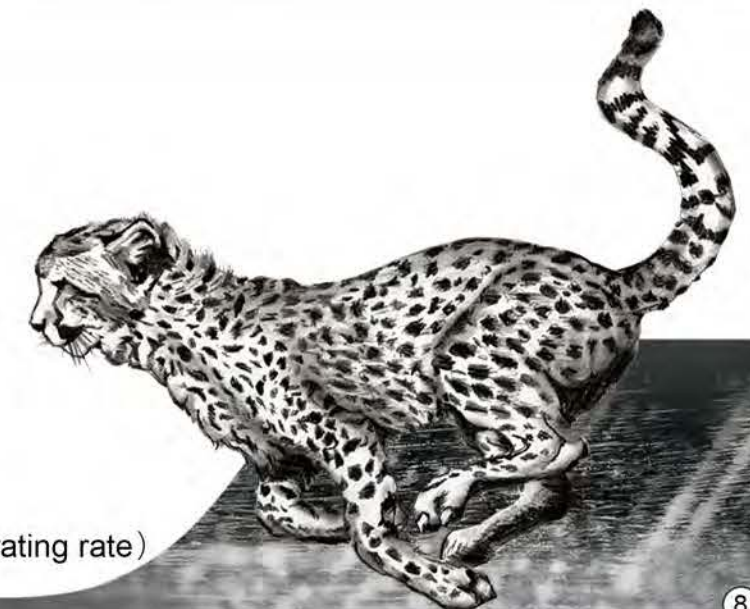

VTW-540 MACHINE DIMENSION DRAWING

VTW-755 MACHINE DIMENSION DRAWING



Auto Pallet Changer

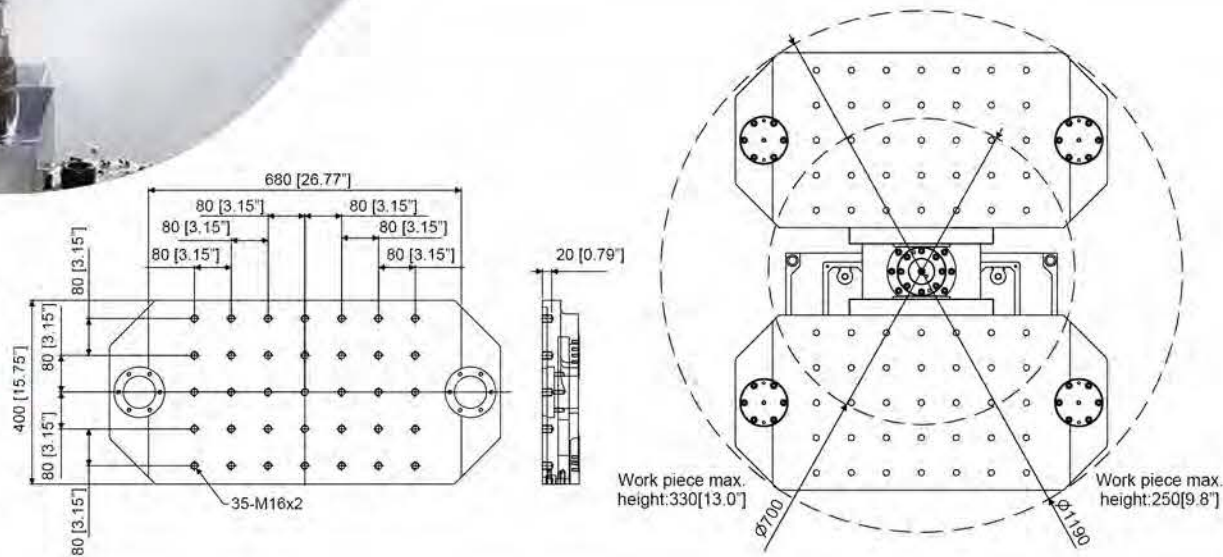

Auto Pallet Changer

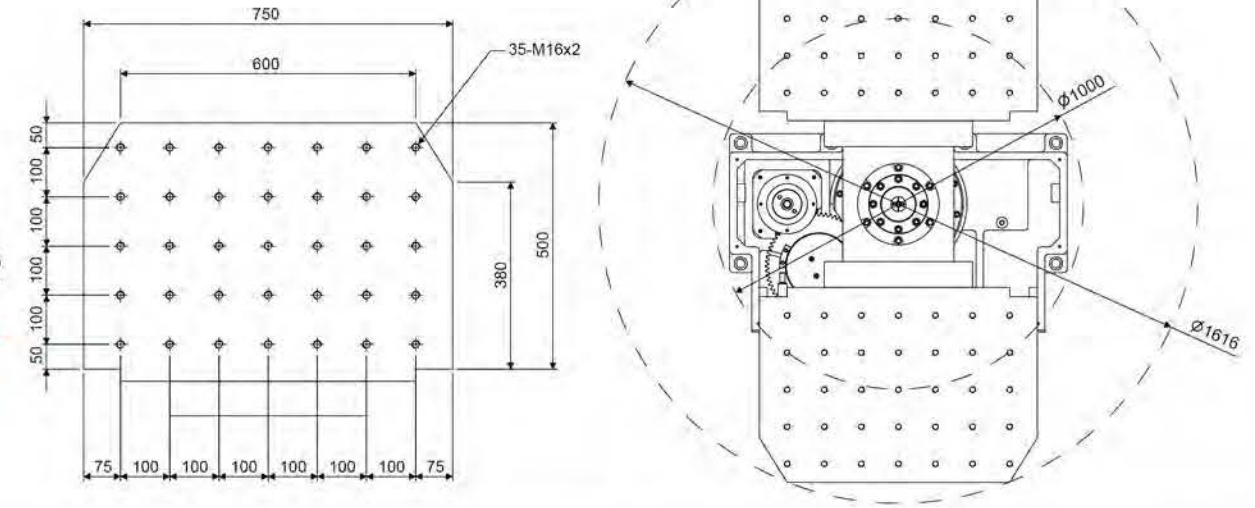

MOTOR POWER -TORQUE DIAGRAM

MOTOR POWER-TORQUE DIAGRAM

MITSUBISHI AC Spindle Motor-SJ-VL11-10FZT
Output Power-Speed & Torque-Speed Characteristic

FANUC AC Spindle Motor-ai SERIES3.
Output Power-Speed & Torque-Speed Characteristic

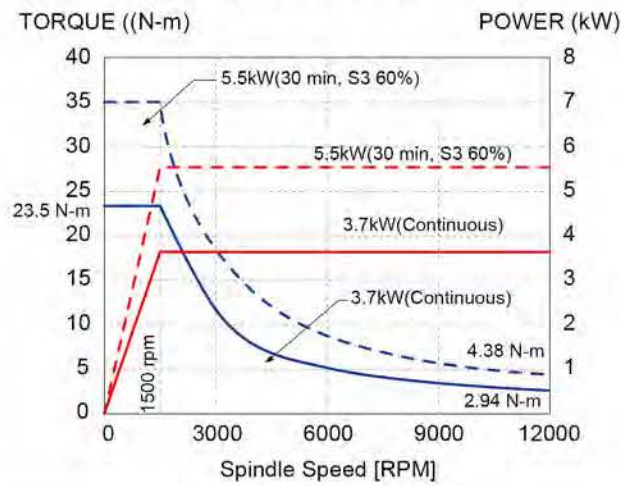
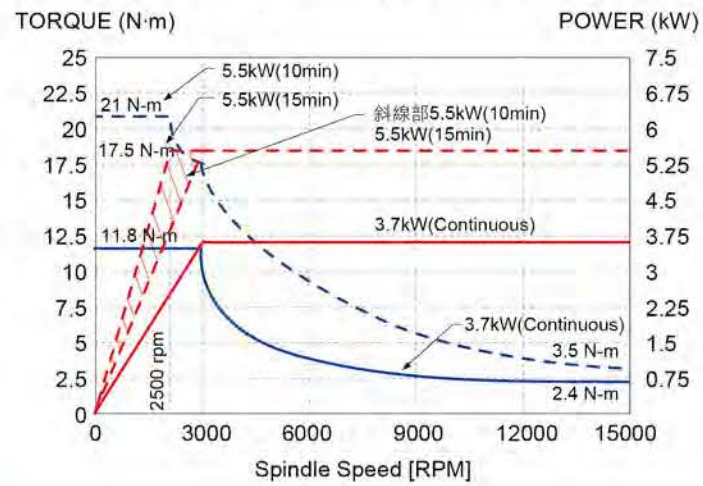

Fanuc Bii 112S/15000

Mitsubishi SJ-2B4357TKH

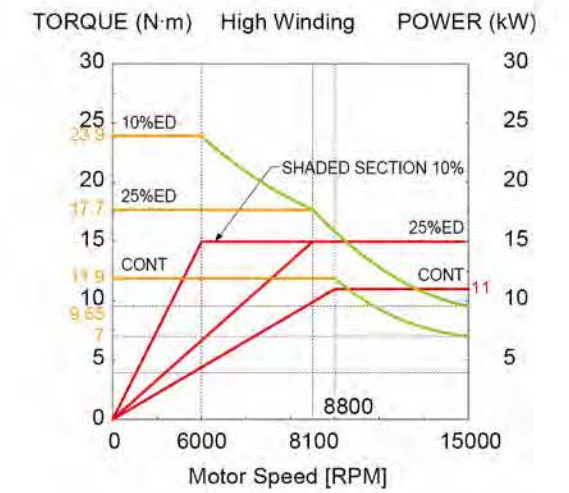
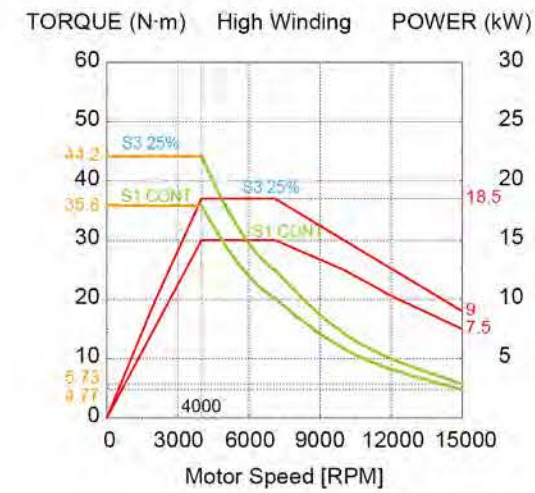

DIMENSION

DIMENSION

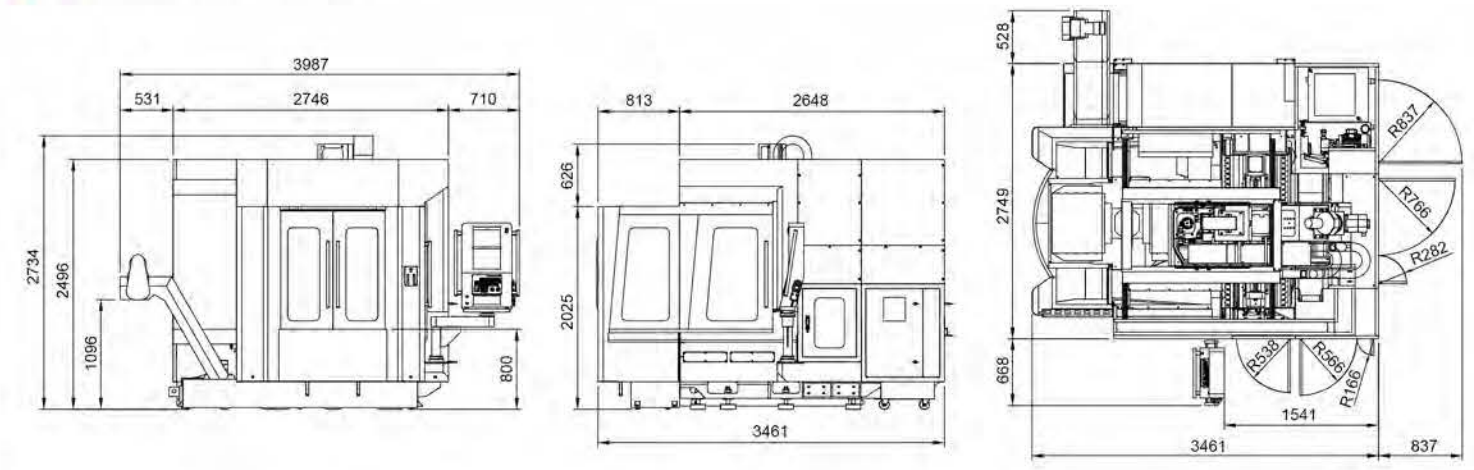
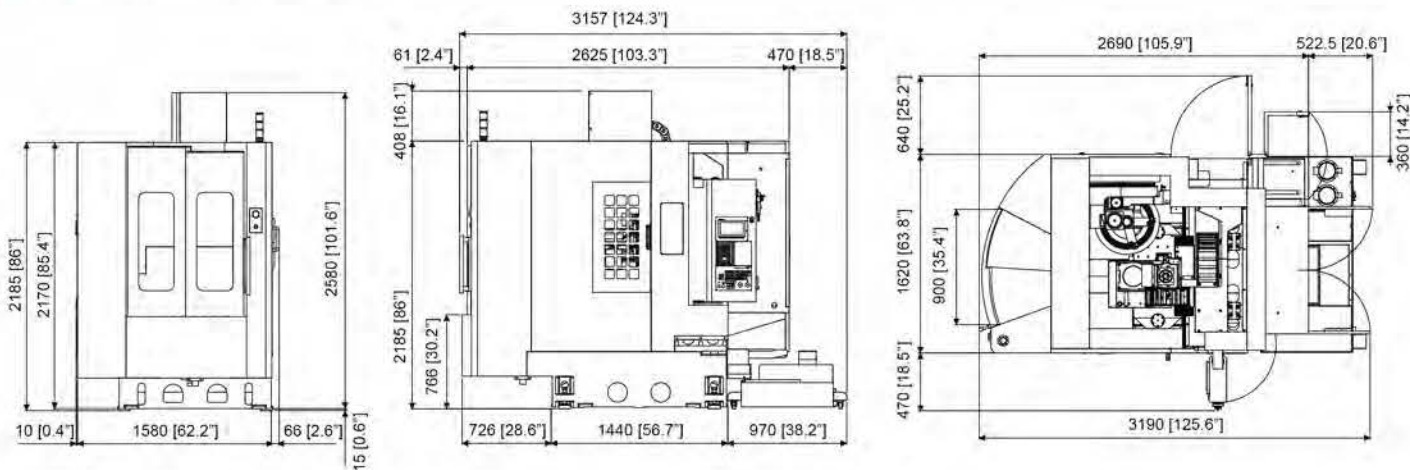



- 1.Communication Box 2.Paintball Gun Handle 3.Motorcycle Cylinder 4.Bicycle Stem
- 5.Paintball Gun Body 6.Bicycle Q/R Clamp 7.Bicycle Q/R Clamp 8.Hydraulic Capliers
- 9.Motorcycle Scapular 10.Oil Block 11.Hydraulic Housing 12. Bicycle Stem Base

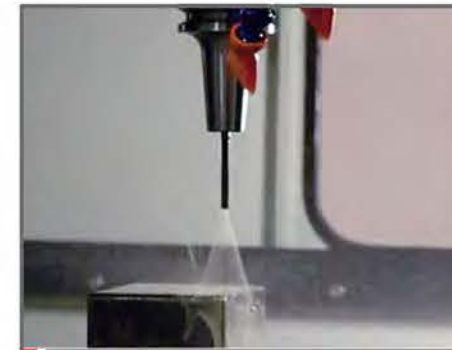

Coolant through spindle (option)
Allow chip removable when do deep hole drilling.



LED work light
Extend lamp life and save energy.



Manual pulse generator
Make operation friendly.



Air gun / Coolant gun
Clean workpiece or chip inside the machine after machining.



Spindle oil cooler (option for VTW-540)
Restrain heat generation during long time machining.



Rotary table (option)
For multi-face machining.



Auto door (option)
Combine with automation to reduce opening / closing time.



Workpiece measurement (option)
Inspect parts on line, reduce defective part.



Tool breakage detector (option)
Improve the efficiency of machine tools.

Integral Equipment Satisfy Your Machining Requirement.

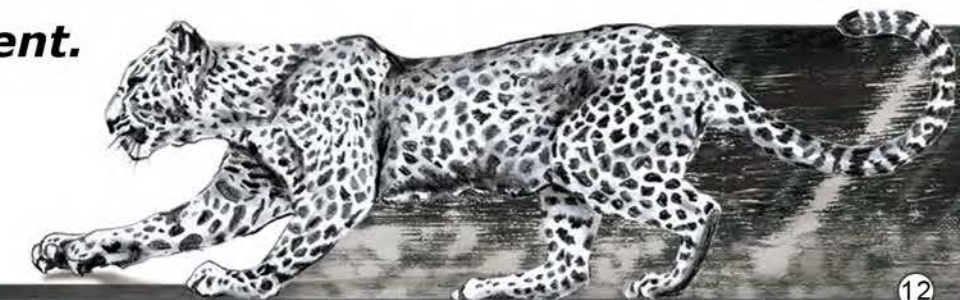



Facing		VTW-540
Material		
S50C		
Spindle speed		
2578 rpm		
Cutting feedrate		
935 mm/min		
Cutting width		
Ø50 mm		
Chip removal		
107 cc/min		

Drilling		VTW-540
Material		
S50C Aluminum 6061		
Spindle speed		
1600 rpm 12000 rpm		
Cutting feedrate		
320 mm/min 240 mm/min		
Cutting width		
Ø18.5 mm Ø1.6 mm		
Chip removal		
86 cc/min 0.5 cc/min		

Tapping		VTW-540
Material		
S50C Aluminum 6061		
Spindle speed		
270 rpm 210 rpm		
Cutting feedrate		
540 mm/min 525 mm/min		
Tap dimension		
M14P2 M18P2.5		

Boring		VTW-540
Material		
Aluminum 6061		
Spindle speed		
4800 rpm		
Cutting feedrate		
480 mm/min		
Cutting width		
Ø20 mm		
Chip removal		
2.88 cc/min		

Ending milling		VTW-540
Material		
S50C		
Spindle speed		
2100 rpm		
Cutting feedrate		
900 mm/min		
Cutting width		
Ø20 mm		
Chip removal		
108 cc/min		

TRAVEL	VTW-540	VTW-755
X/Y/Zaxis	500 / 400 / 350 mm	750 / 550 / 500 mm
Spindle nose to pallet surface	180 ~ 530 mm	100 ~ 600 mm
Column surface to spindle center	485 mm	500 mm
Pallet top height (from the floor)	800 mm	820 mm

PALLET	VTW-540	VTW-755
Pallet size	680 x 400 mm	750 x 500 mm
Max. work piece height	330 mm	500 mm
Max. load	150 kg	350 kg
Configuration	35-M16 Pitch 80 mm	35-M16 Pitch 100 mm

SPINDLE	VTW-540	VTW-755
Spindle speed	15000 rpm	12000 rpm
Spindle torque (cont. / 15 mins)	11.8 / 17.5 N·m	44.8 / 83.3 N·m (LOW) 35.8 / 44.2 N·m (HIGH)
Spindle taper	BT 30	BBT 40
Pull stud	MAS403 P30T-145	MAS403 P40T-145

FEED	VTW-540	VTW-755
Rapid feedrate (X/Y/Z axis)	48 m/min	48 m/min (option 60 m/min)
Cutting feedrate (X/Y/Z axis)	10 m/min	10 m/min
Ballscrew dia.	Ø32 mm	Ø40 mm

AUTOMATIC PALLET CHANGER(APC)	VTW-540	VTW-755
Number of pallet	2	2
Pallet change system	Rotary	Rotary

AUTOMATIC TOOL CHANGER (ATC)	VTW-540	VTW-755
Tool change system	Arm type	Arm type
Number of tools	24T	30T
Max. tool diameter (with / without adjacent tool)	Ø65 / Ø80 mm	Ø75 / 135 mm
Max. tool length	200 mm	250 mm
Max. tool weight	3 kg	8 kg
Tool to tool	1.2 sec	2 sec(50 Hz) 1.8 sec(60 Hz)

MOTOR	VTW-540	VTW-755
Spindle motor	3.7 / 5.5 kW(S3-25%)	7.5 / 15 kW (LOW) 15 / 18.5 kW (HIGH)
Coolant pump	530 W x1pcs, 850 W x1pcs	530 W x1pcs, 850 W x1pcs

SUPPLY	VTW-540	VTW-755
Voltage	200-220 V (50 / 60 Hz)	200-220 V (50 / 60 Hz)
Power supply	20 kVA	35 kVA
Air pressure & volume	0.6 MPa , 350 liters/min	0.6 MPa , 350 liters/min
Coolant tank	190L	230L

DIMENSION	VTW-540	VTW-755
Floor space	1600 x 2685 mm	3480 x 2800 mm
Machine height	2750 mm	2900 mm
Machine weight	4000 kg	10000 kg

Standard Accessories

- 15000 rpm direct-driven spindle (VTW-540)
- 12000 rpm built-in spindle (VTW-755)
- Arm type 24T ATC system (VTW540)
- Arm type 30T ATC system (VTW-755)
- Chain type chip conveyor (VTW-755)
- Coolant system
- Fully enclosed splash guard
- Work lamp
- Auto lubrication system
- Spindle air blast
- Spindle air curtain
- Spindle oil cooler
- Heat exchanger for electrical cabinet
- Tools & tool box
- Leveling bolts & pads
- Operation & maintenance manual
- Air gun
- Water gun

Optional Accessories

- 20000 rpm direct-driven spindle (VTW-540)
- 24000 rpm built-in spindle (VTW-540)
- 15000 rpm built-in spindle (VTW-755)
- Coolant through spindle
- 4th axis system
- MPG
- Automatic door
- Workpiece measurement device
- Tool breakage detector
- Transformer

* The company reserves the right to change the mechanical specifications, accessories and appearance without prior notice.

